

Fokker E.III Fighter Aircraft

BALSAWOOD AIRPLANE INSTRUCTION MANUAL

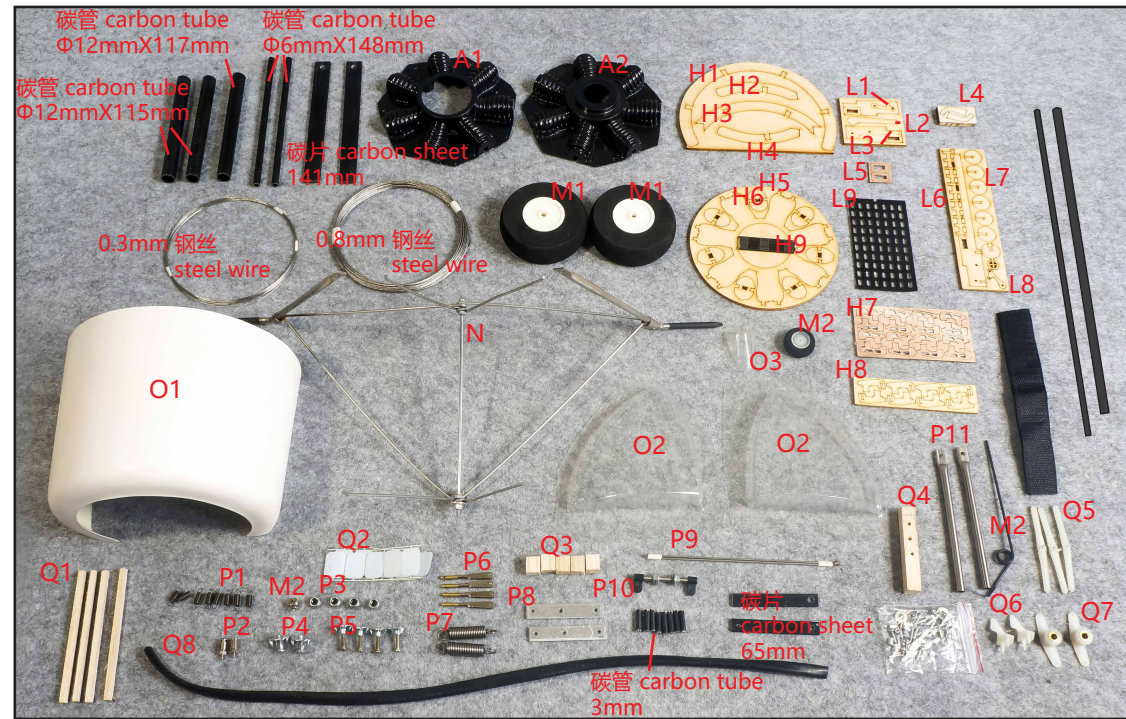

参数

翼展: 1520mm
机长: 1170mm
起飞重量: 2.3-3.0kg

Specification

Wingspan: 1520mm
Fuselage Length: 1170mm
Flying weight: 2.3-3.0kg

推荐配置:

马达: 2820-3520KV 1000-600KV
电调: 40-60A
舵机: 37g*2 17g*2
桨叶: 10-13 inch
电池: 3S-4S 2200-4000mAh
通道≥4CH/5CH
油动引擎: 40-56 class methanol or same class engine

Suggested Equipment:

Motor: 2820-3520KV 1000-600KV
ESC: 40-60A
Servo: 37g*2 17g*2
Prop: 10-13 inch
Battery: 3S-4S 2200-4000mAh
Radio ≥ 4CH/5CH
GP: 40-56 class methanol or same class engine

机身组装 Wing Assembly Diagram

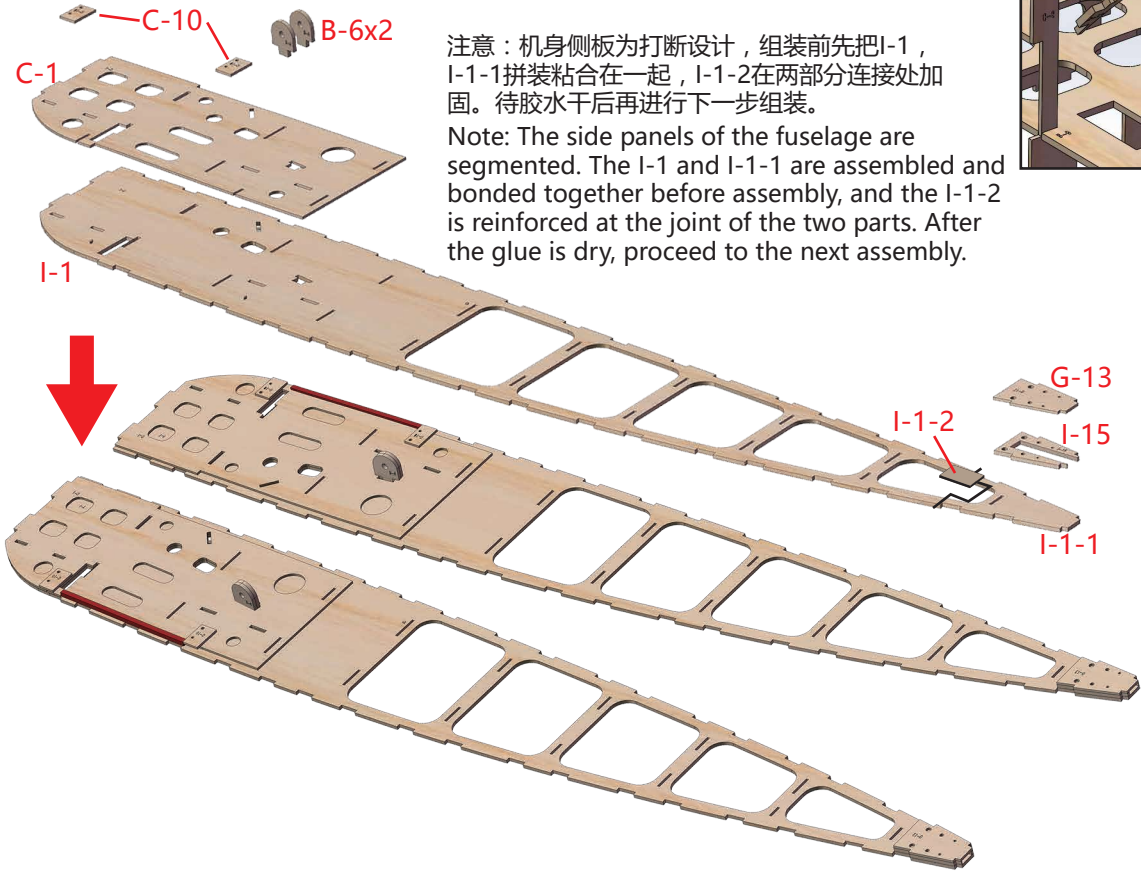

注意: 机身侧板为打断设计, 组装前先把I-1, I-1-1拼装粘合在一起, I-1-2在两部分连接处加固。待胶水干后再进行下一步组装。

Note: The side panels of the fuselage are segmented. The I-1 and I-1-1 are assembled and bonded together before assembly, and the I-1-2 is reinforced at the joint of the two parts. After the glue is dry, proceed to the next assembly.

先安装B-8的爪牙螺母再拼装到机身。
First install the B-8's claw nut and assemble it in front of the fuselage.

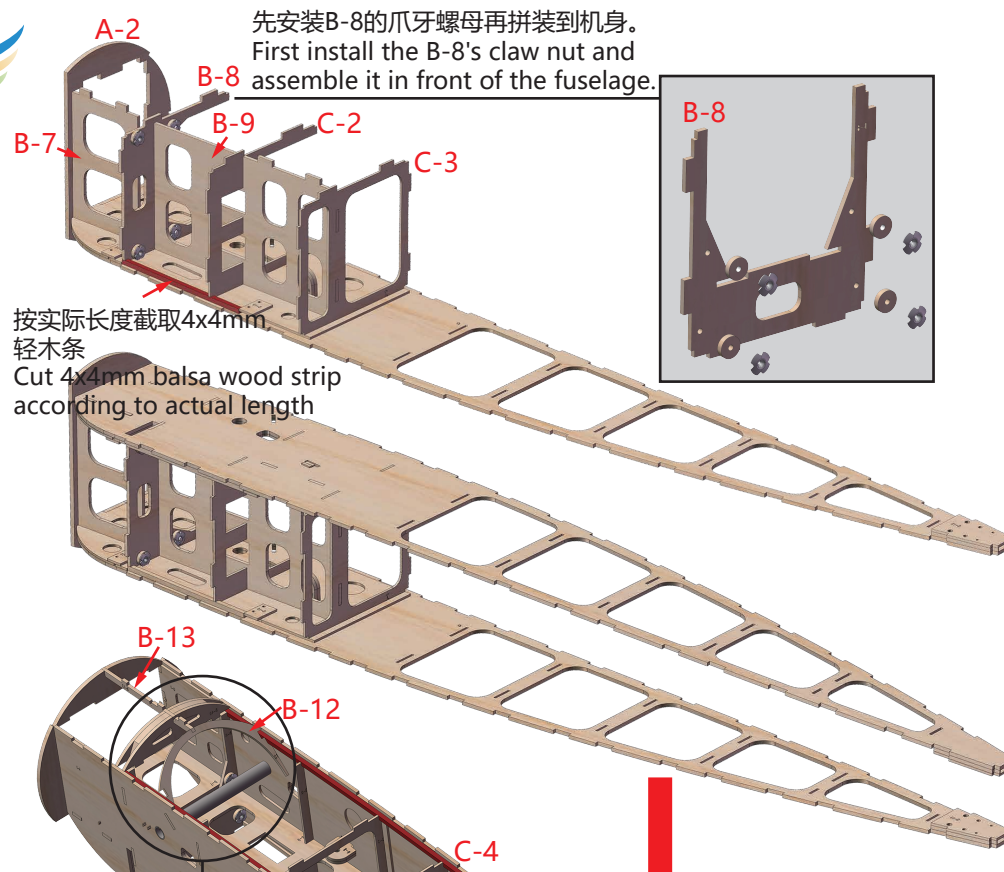

按实际长度截取4x4mm 轻木条
Cut 4x4mm balsa wood strip according to actual length

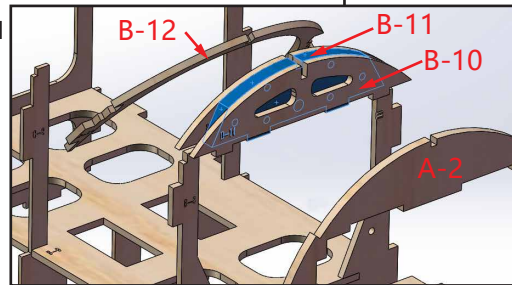

桐木条 paulownia bar 4X4mm
按实际长度截取
Cut according to actual length

桐木条 paulownia bar 4X4mm
按实际长度截取
Cut according to actual length

碳管 carbon tube Φ12X117mm

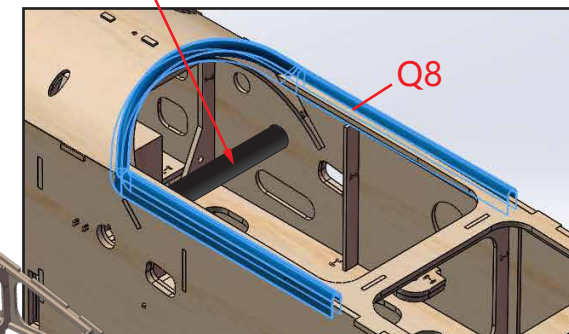

马达座安装图示 Motor mount installation

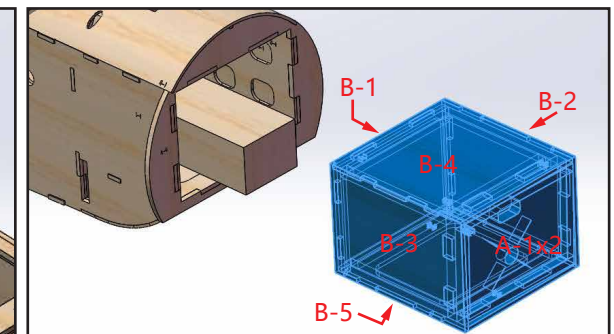

马达座安装好后, 插入机身头部, 然后根据所用马达长度大小调整马达伸出长度, 然后用大量胶水粘合马达座到机身。
After the motor mount is installed, insert it into the fuselage head, and then adjust the extension length of the motor mount according to the length of the motor used, and then bond the motor base to the fuselage with a large amount of glue.

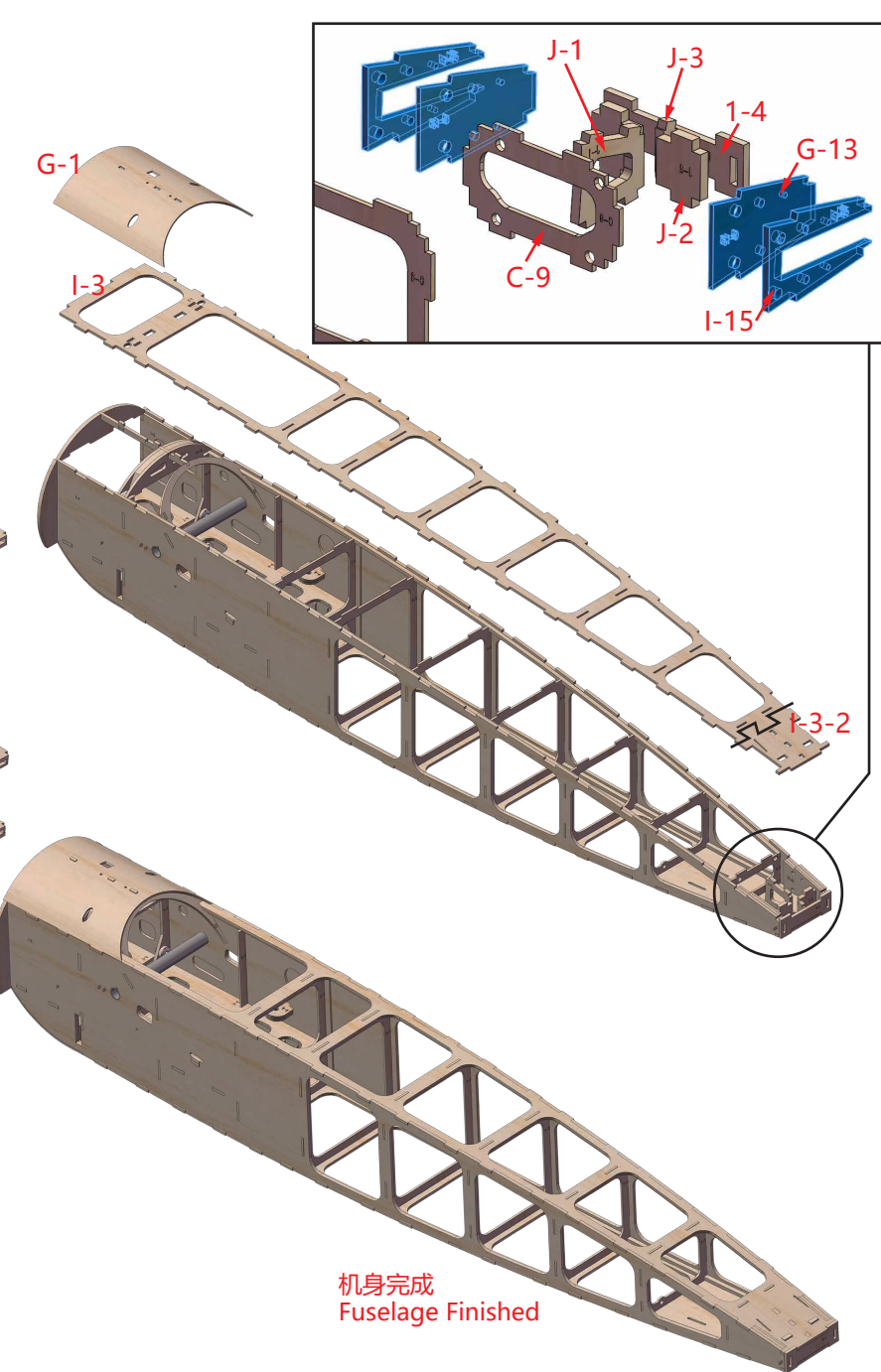

机翼组装 Wing Assembly Diagram

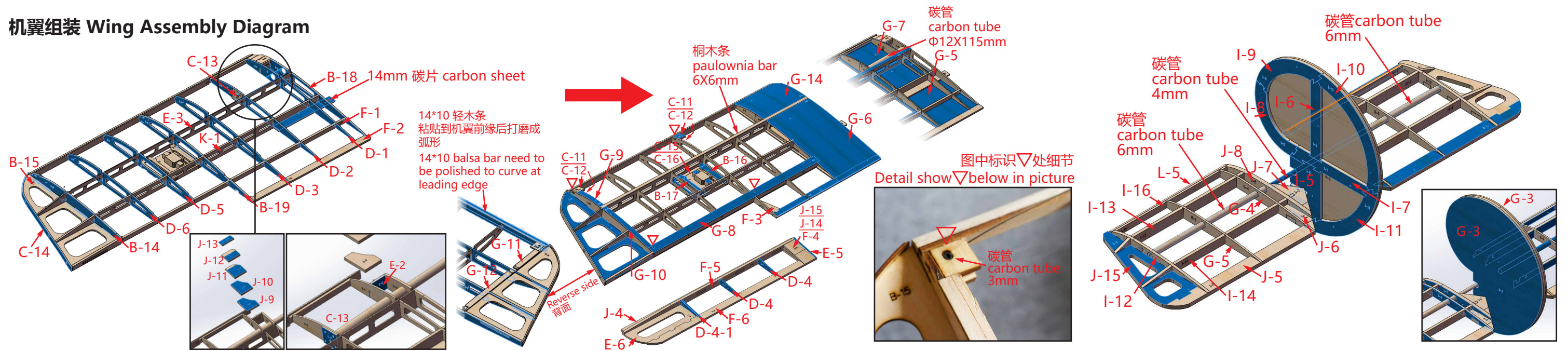

像真机枪，引擎组装 Assembly of scale engine and machine gun

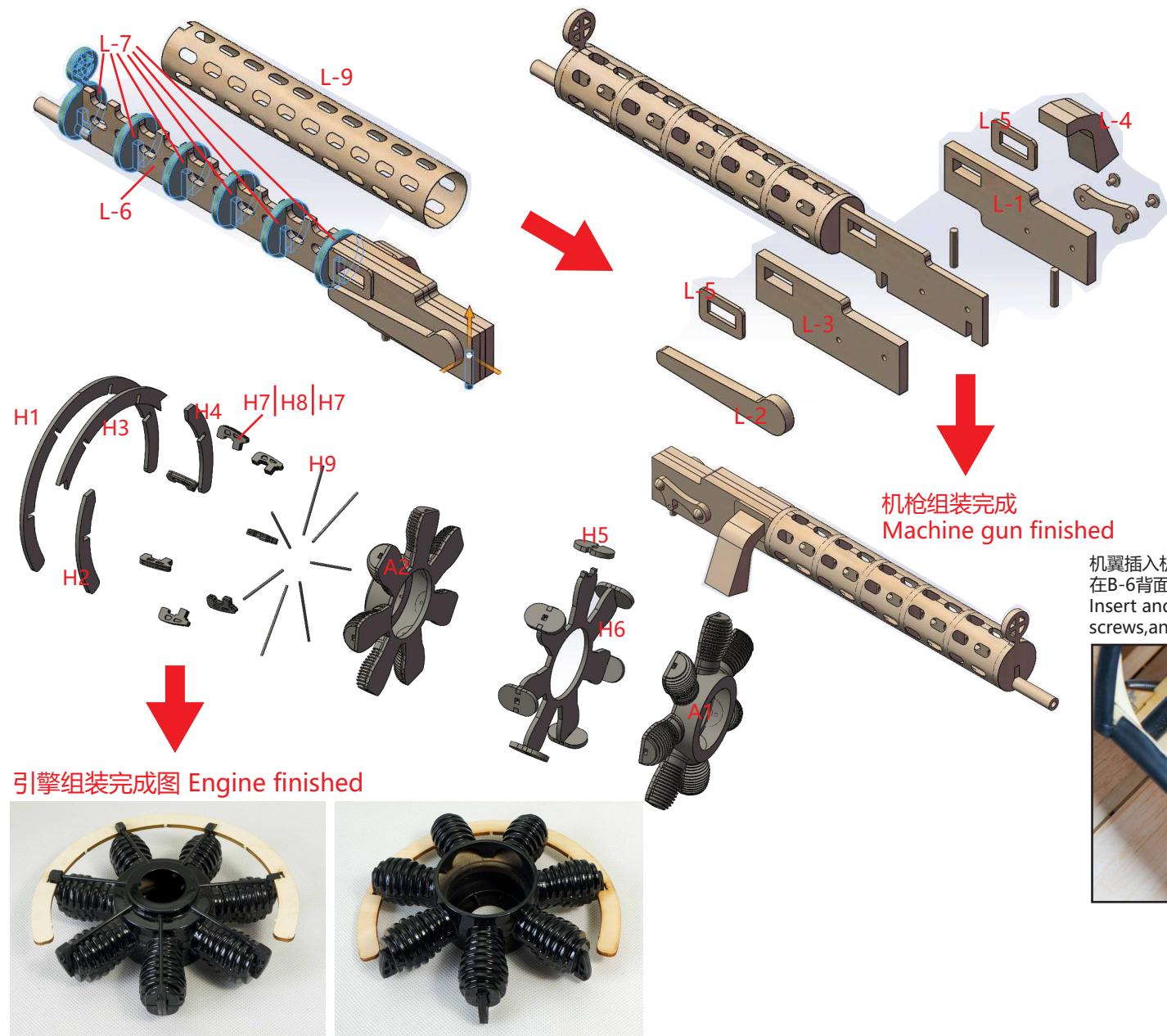

各部件组装 Accessories Assembly Diagram

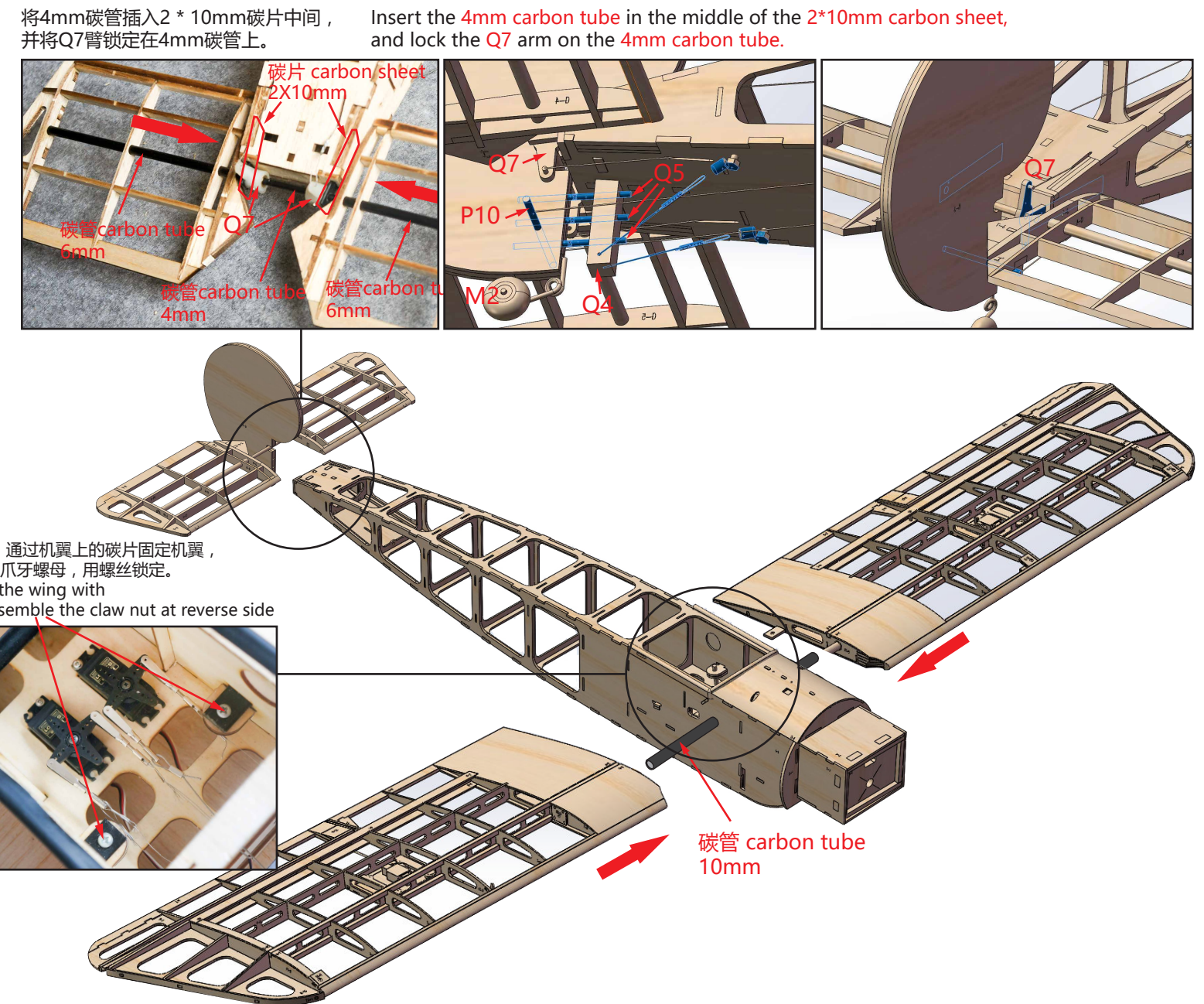



机翼舵机安装示意图 Assembly diagram of servo on the wing

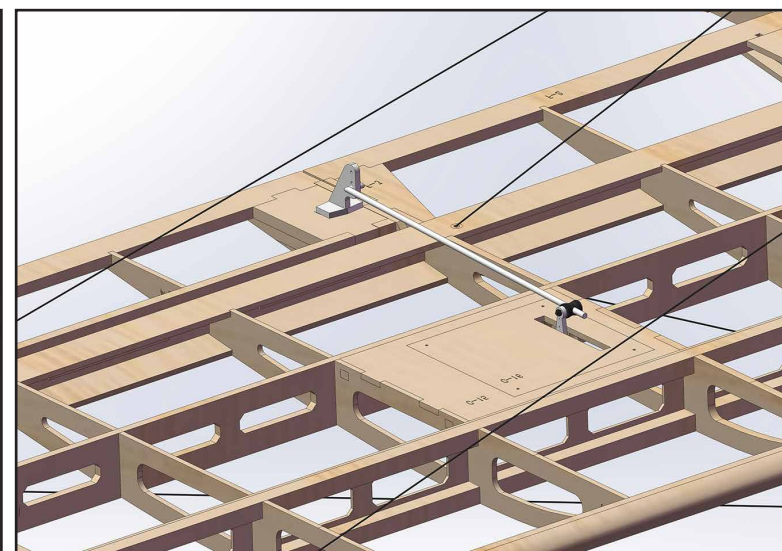
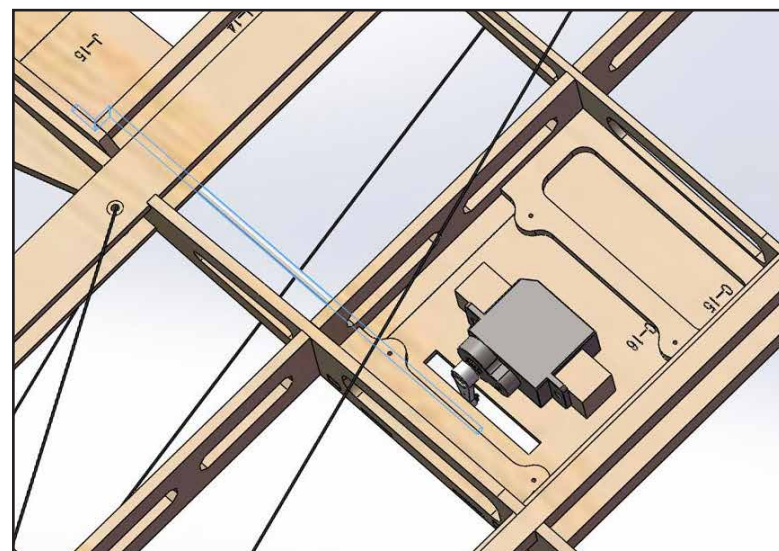

机翼拉线安装示意图 Assembly diagram of wing wiring

拉线为0.8mm钢丝。

拉线从①起，穿入孔②，牵引到③处结束，前后各两条拉线。左右相同安装。

Use the 0.8mm steel wire as wiring
Wiring start from 1, insert into hole 2 and directly pull to 3 over, there are totally two wiring respectively at leading and trailing edge. Pls note the wiring of the left and right wing are same way.

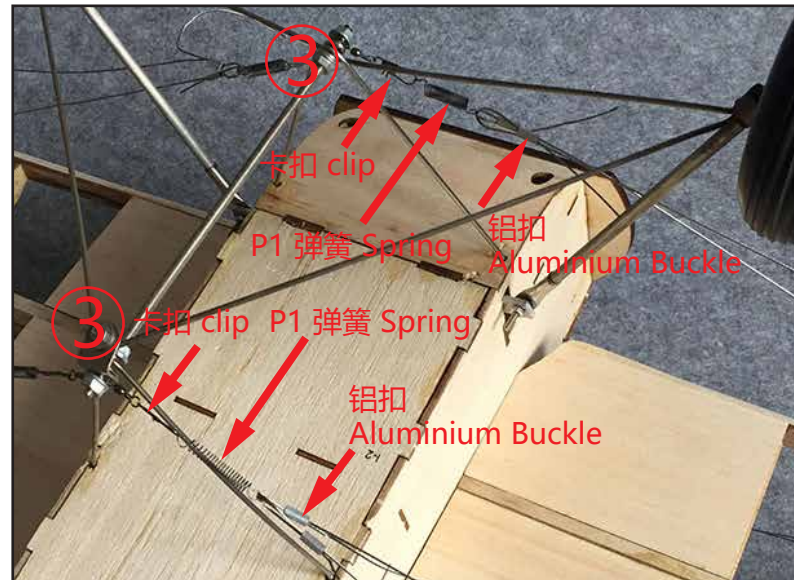
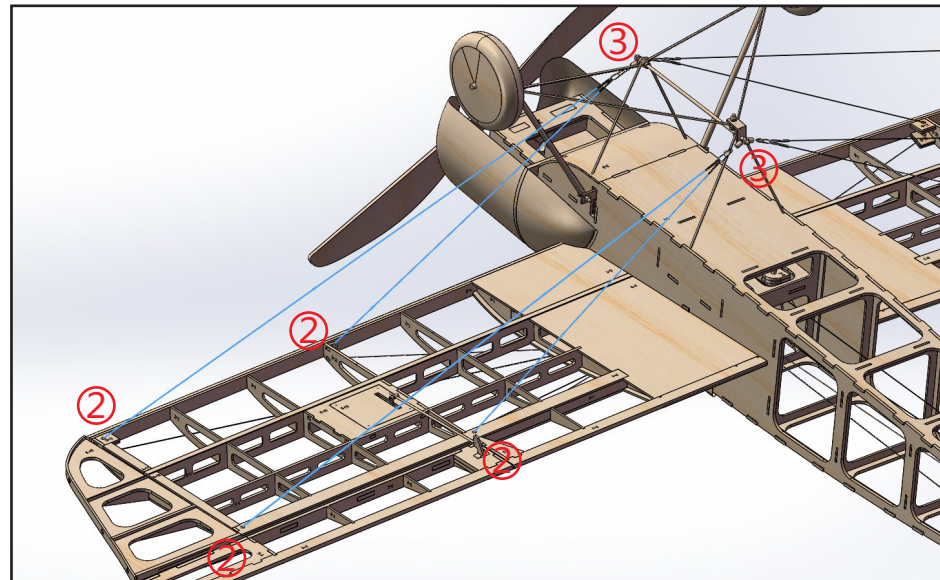
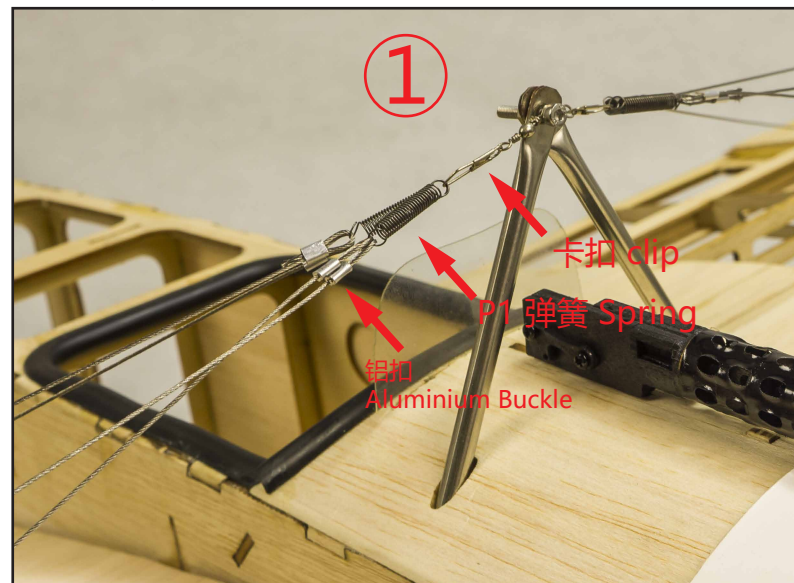
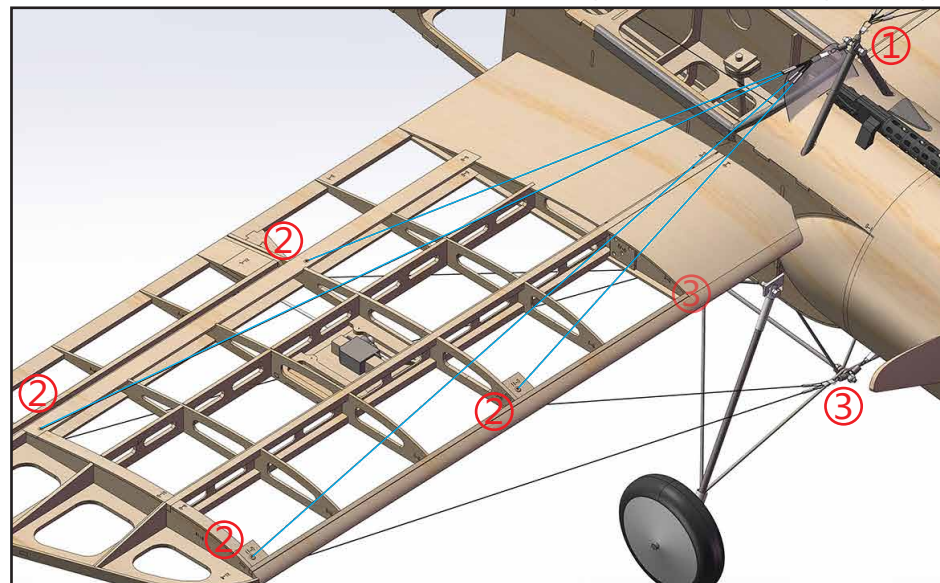

头罩，像真件（像真机枪 像真引擎）
Assembly diagram of the cowling and scale parts

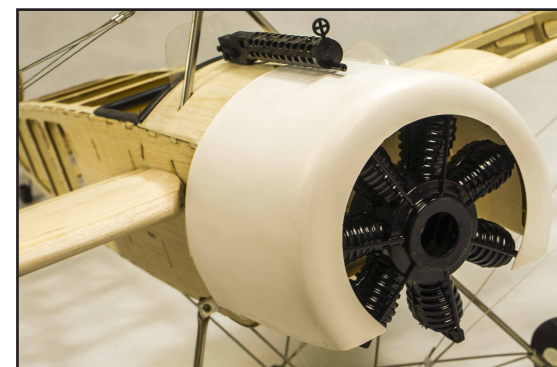
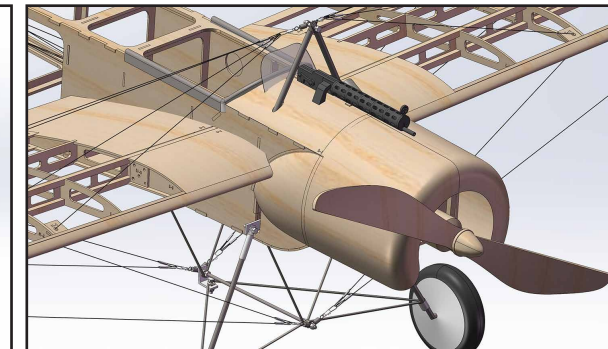
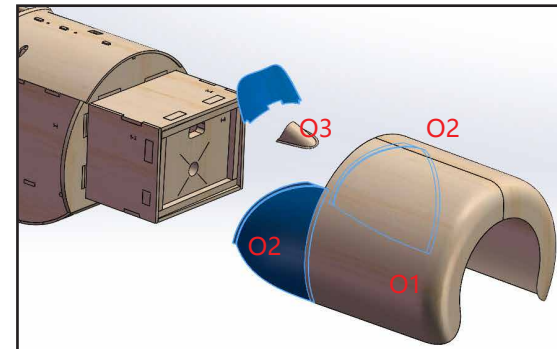

起飞重心展示
Display the C.G.

